



The Roofing Store



## BRANCH LOCATIONS

### Albany

2 Cowley Place, Albany,  
Auckland  
Ph: 09 972 0060

### Christchurch

17 Hammersmith Drive,  
Wigram, Christchurch  
Ph: 03 281 8214

### Hamilton

549A Te Rapa Road,  
Hamilton, Waikato  
Ph: 07 282 0710

### Manukau

Cavendish Drive, Wiri,  
Auckland  
Ph: 09 277 2717

### Palmerston North

3 Mahinui Street, Feilding,  
Manawatu  
Ph: 06 323 6037

### Wellington

38 Waione Street, Petone,  
Lower Hutt, Wellington  
Ph: 04 974 5762

## Contents

About The Roofing Store.....	01
What We Do.....	02
Super Seam.....	04
Standing Seam.....	06
Interlocking.....	10
Weatherboard.....	12
Long Run Profiles.....	14
Kiwicolour Range.....	16
Gallery.....	20



## About The Roofing Store

**The Roofing Store was established to offer a better solution to all New Zealanders, ensuring the comfort and protection of your home through the use of new and innovative products.**

Our products range from long run roofing, metal tiles, architectural roofing and cladding systems, to rainwater goods and all the accessories required. With so much to choose from, we can match any application or aesthetic requirement.

We can meet the roofing needs of home owners, roofers, builders and plumbers, through to architects, developers and commercial construction. Our company is expanding rapidly, with 9 branches nationwide. We use KiwiColour® which comes with over 40 years experience in pre-painted steel. Our range consists of Vitor+, Vitor+ZX and Lux colours. Each product has been developed to specifically suit different environmental conditions within New Zealand, and all offer exciting colours which ensures that you will find the colour you're looking for. All products have been tested against the harsh New Zealand environment, comply with standard (AS/NZS 2728) and come with a full and extensive warranty.

Our commitment to the steel roofing industry has been further demonstrated by our investment of in-house roll forming and pressing facilities. We will continue to expand our investment in plants and machinery to increase our range of products and geographic coverage. The Roofing Store is experiencing growing success through distributing steel roofing materials and accessories direct to installers and home owners who benefit from receiving the highest quality products at competitive prices.



## What We Do

**We are confident you will find TRS is your one stop shop for all of your specifications, Metal Roofing and Cladding requirements. We have tech savvy staff at each of our outlets who can offer further clarification and technical solutions.**

We can supply the following architectural profiles for roof and/or wall cladding from the TRS range.

- Angle Seam
- Double Standing Seam
- Roll Cap
- Roll Seam
- Super Seam
- Interlocking Panels
- Weatherboard Step Panel
- Custom Facade Systems
- Long Run Range

TRS will accommodate any custom requirements you may have while guiding you through the entire process from the design to installation.



The Roofing Store



## TRS Super Seam



**Super Seam is our latest tray system for roofing & cladding providing sleek lines and wider pans giving off an elegant European look without the additional cost of a substrate thus reducing costs.**

Super Seam is a tray Roofing & Cladding installed on purlins or battens. Trays are snapped together using the hidden clips utilizing the specially designed over and under of the Super Seam Tray.

Super seam allows a much greater flexibility in design than other standard long run profiles. Tray sizes may vary depending on design requirements.

Super seam is an ideal cladding for roof, facade, soffit and fascia areas. Using traditional European techniques Super seam will enhance the style or type of building. Because of super seams flexibility with complex designs and shapes it can be handled relatively with ease.

Super seam is ideal for use on new homes, reroofing, and existing buildings where a stylish versatile cladding system is desirable.

### APPLICATION

Areas of application could include:

- + Roof
- + Facade
- + Turrets
- + Domes
- + Soffits
- + Fascias

Super seam is also ideal for creating features as:

- + Chimney cladding
- + Flashings
- + Interior feature walls
- + Pillar & column surrounds
- + Gable and infill
- + Gothic style homes
- + Entrance canopies

## PROFILE INFORMATION

Super seam is available in a variety of widths. We can offer 250 & 450 Wide pans as our most cost effective widths for manufacture and installation. Please consult with The Roofing Store for alternative tray sizing.

## PANEL DETAILS

- Suitable for wall cladding and roofs with a minimum pitch of 3°
- Variable pan from 200 to 630 mm
- Seam height - 45mm overall Height
- Can be manufactured in full range of materials:
  - Copper (Plywood Substrate required)
  - Stainless Steel
  - Titanium Zinc
  - Aluminum 0.80g
  - VITOR+, VITOR+ZX or LUX - 0.55g Steel

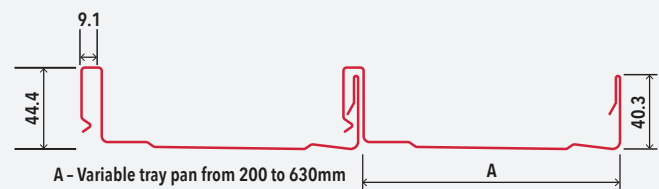

Minimum pitches are dependent on factors like tray lengths, local conditions like snow zones, wind and rainfall intensities. Please consult with us for recommendations.

A maximum tray length depends on the material used, roof pitch and local conditions.





## TRS Standing Seam

**Standing Seam is a wide tray roofing system which is the ideal cladding system for roof, facade, soffit and fascia areas. With the use of traditional European techniques Standing Seam will enhance the style of any structure.**

Trays are seamed together using a variety of seam and cap methods, depending on functional and aesthetic requirements.



### APPLICATION

Areas of application could include:

- + Roof
- + Facade
- + Turrets
- + Domes
- + Soffits
- + Fascias

Standing seam is also ideal for creating features as:

- + Chimney cladding
- + Flashings
- + Interior feature walls
- + Pillar & column surrounds
- + Gable canopies



**DIMENSIONS** - We can offer our clients the choice of Classic 25mm seam height (South Island only) or the 38mm seam option. The maximum tray length depends on the material used, roof pitch and local conditions. We can roll form our 25mm seam trays (South Island) on site using our mobile machine to minimize lead time, freight damages and waste.

**DESIGN CONSIDERATIONS** - When using Standing Seam consideration should be given to the following: Material type, Preferred profiles, Rib centers, Roof shape, Roof pitch, Radius of curved roof, Wind loads, Snow and rainfall zones. Because the Standing Seam profile is fixed to a solid substrate and it is protected from any wind loads from underneath (apart from structural) Standing Seam profile is only subject to wind suction load.

**SOLID SARKING** - Standing Seam (excluding Super Seam) requires either solid timber or plywood sarking for total support. We recommend plywood minimum 15mm thick or solid timber sarking 25mm thick. Please consult with the local authorities for treatment requirements. Please note to prevent damages to your roof oil based treatments must be avoided.

**UNSUPPORTED/FIXING ON PURLINS** - Super Seam does not require a solid substrate due to its unique clip system. Purlin spacing will vary depending on pan widths, materials selection and specific design elements.

**FIXING ON PLYWOOD OR TIMBER SARKING** - Plywood or the solid timber sarking should be fixed with screws to the rafters. No nails, staples or other type of fixings should be used as consideration should be given to the possibility of nail popping. Screws should be at 150mm spaced around the edges and 250mm spaced on the intermediate support. Plywood should be fixed with 3mm space between the sheets to allow for expansion and 10-20mm between the timber planks for the solid sarking allowing for ventilation. Ventilation for the roof space is strongly recommended to avoid condensation.

**UNDERLAYS** - We recommend the use of anti-abrasive breathable type underlay. Refer to the local range of products available from Archtech.

**FIXINGS** - Standing Seam profiles are fixed with concealed metal clips. The clips are screwed or nailed with special roofing nails straight into the sarking. For Angle and Double Standing Seam screws or nails can be used. Roll Cap and Roll Seam are fixed with tex head roofing screws. We recommend the use of stainless steel nails only and galvanized screws due to contact with treated timber.



## SEAM OPTIONS

TRS offers the Standing Seam system in five popular profiles which are both modern looking and flexible in design. These profiles are cost effective to manufacture and install. All dimensions below nominal in mm.

### 1. ANGLE SEAM

- Suitable for wall cladding and roofs with a minimum pitch of 3°
- Variable pan A from 200 to 730mm
- Seam height - 38.1mm (1.5 inch)
- Can be manufactured in the following materials only:
  - Copper
  - Aluminium
  - Zinc
  - VITOR+, VITOR+ZX or LUX
  - Stainless Steel

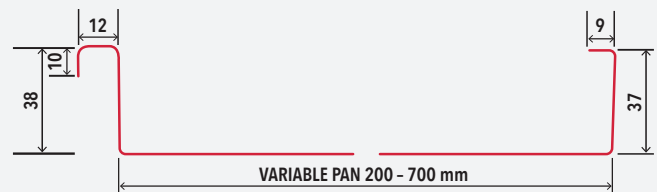

### 2. DOUBLE STANDING SEAM

- Suitable for wall cladding and roofs with a minimum pitch of 3°
- Variable pan A from 230 to 730mm
- Seam height - 25.4mm (1 inch) or 38.1mm (1.5 inch)
- Can be manufactured in the following materials only:
  - Copper
  - Aluminium
  - Zinc
  - Stainless Steel

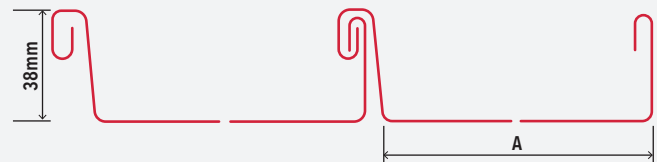

### 3. ROLL SEAM

- Suitable for wall cladding and roofs with a minimum pitch of 3°
- Seam height - 25.4mm (1 inch) or 38.1mm (1.5 inch)
- Can be manufactured in the following materials only:
  - Copper
  - Aluminium
  - Zinc
  - VITOR+, VITOR+ZX or LUX
  - Stainless Steel
  - Titanium

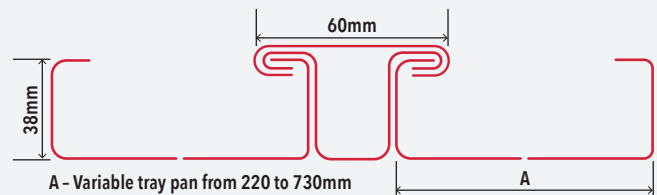

### 4. ROLL CAP

- Can be manufactured in the following materials only:
  - Copper
  - Aluminium
  - Zinc
  - VITOR+, VITOR+ZX or LUX
  - Stainless Steel
  - Titanium

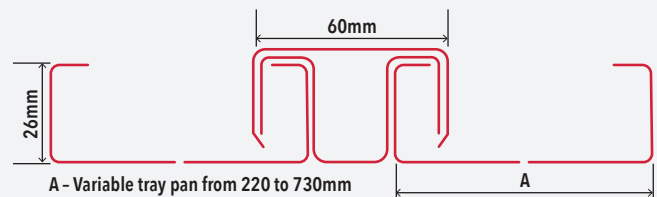

### 5. SUPER SEAM

- Suitable for wall cladding and roofs with a minimum pitch of 3°
- Seam height - 46mm (1.75 inch)
- Can be manufactured in the following materials only:
  - Copper
  - Aluminium
  - Stainless Steel
  - VITOR+, VITOR+ZX or LUX
  - Stainless Steel
  - Titanium



## FIXING CLIPS

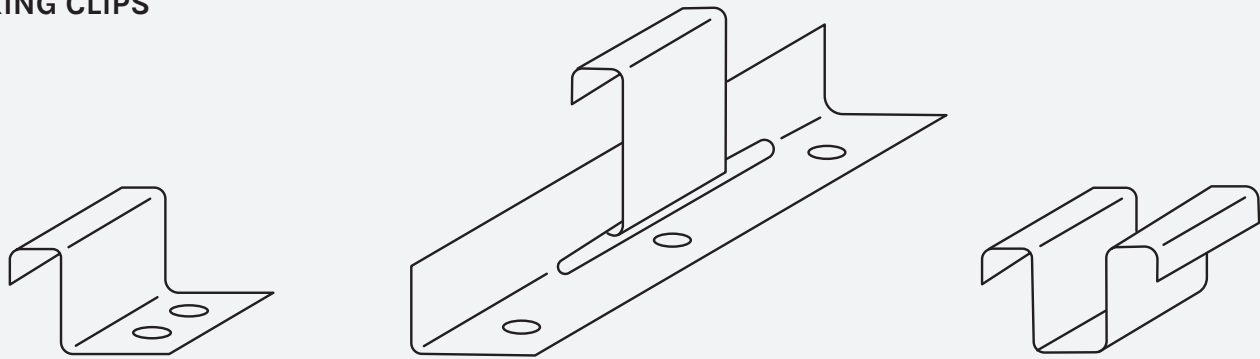

## THERMAL EXPANSION AND CONTRACTION

The rate of thermal expansion and contraction varies between the metals and also the colour of the product. To accommodate this standing seam trays are fixed with combination of fixed and sliding clips.

MATERIAL	EXPANSION (mm/m-C)	70°C CHANGE OVER mm TRAY (mm)
Steel	0.011	7.7
Aluminum	0.023	16.1
Zinc	0.022	15.4
Copper	0.017	11.9

Factors which can affect the lengths of the trays are:

- Manufacturing location
- Access to work area
- Design and detailing
- Choice of profile

Please consult with TRS for technical advice.





## TRS Interlocking

**The TRS Interlocking Panel system is a wall cladding, fascia, soffit & interior system installed with a ventilated air space. With negative detailing and straight lines it gives a crisp look to any project from commercial to residential.**

It involves laying interlocking panels horizontally or vertically on a metal, timber or plastic batten which is fixed to the supporting structure/frame (masonry or metal framing).

The panels are simply connected by the use of an interlocking groove giving the elegant appearance of a recessed joint. They are fixed onto the framework using mechanical fixings which are concealed in the inside edge of the negative groove.



### APPLICATION

Interlocking panels can be applied horizontally or vertically on new homes and existing buildings.

This system is ideal for designs that require a ventilated air space.

Areas of application could include:

- + Facade
- + Chimney cladding
- + Soffits
- + Interior feature walls & ceilings
- + Fascias

## PANEL DETAILS

- Suitable for wall cladding ONLY
- Negative joint sizing: 2-25mm (recommended 15mm min)
- Variable Pan size from 155-240mm unsupported
- Pan size over 240mm will require back support, we will use fire rated POLYFOAM 24mm
- Max panel length - 6m for pre-painted steel; 4m for any other material
- 0.7mm Corten (Rigid air barrier required)
- Can be manufactured in the following materials only:
  - Copper
  - Aluminium
  - Stainless Steel
  - VITOR+, VITOR+ZX or LUX
  - Titanium Zinc

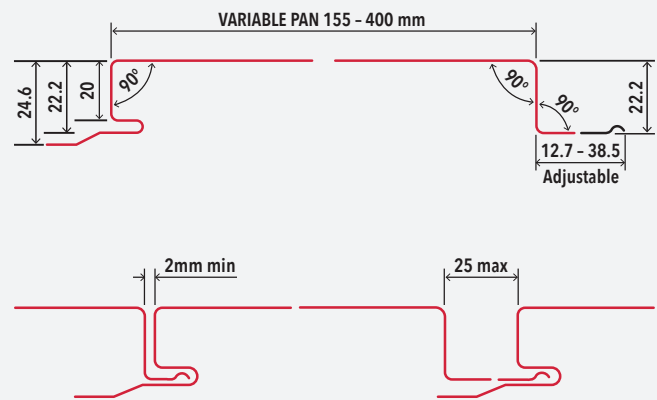

**DESIGN CONSIDERATIONS** - Interlocking Panels can be installed horizontally, vertically or diagonally. A specific feature of this cladding is that it is installed from top to bottom when used horizontally. Special attention is needed to position any penetrations in the walls so that they are aligned with the recessed joints - horizontally and or vertically.

Random panel sizing can be used to achieve an effective look with full panels around joinery/corners and other penetrations. Because of waterproofing requirements, Interlocking Panel cannot be notched around any penetrations.

**FIXINGS** - Interlocking panels are fixed with concealed screws direct to the framework. If the material chosen is copper, titanium zinc, aluminum or stainless steel and the length is long, special sliding clips will be necessary. Please consult with Archtech for further fixing schedules.



### Factors which can affect the lengths of the trays are:

- Manufacturing location
- Access to work area
- Design and detailing
- Choice of profile

Please consult with TRS for technical advice.



## TRS Weatherboard

### **An ideal low-maintenance alternative to timber weatherboards.**

With the appeal of a classic weatherboard & simplicity of installation, our metal weatherboard is a very cost effective and attractive system that gives a classic finish for existing or new buildings.

They are installed as conventional weatherboards over a cavity batten, resembling the look of a traditional bevel back weatherboard.



### **APPLICATION**

Weatherboard Panels offer a classic look for contemporary or traditional designs.

Areas of application could include:

- + Facade
- + Chimney cladding
- + Interior feature walls

## PANEL DETAILS

- Suitable for wall cladding ONLY
- Variable pan A from 115 to 300mm
- Max panel length - 6m for pro-painted steel; 4m for any other material
- 0.7mm Corten (rigid air barrier required)
- Can be manufactured in the following materials only:
  - Copper
  - Aluminium
  - Stainless Steel
  - VITOR+, VITOR+ZX or LUX
  - Titanium Zinc

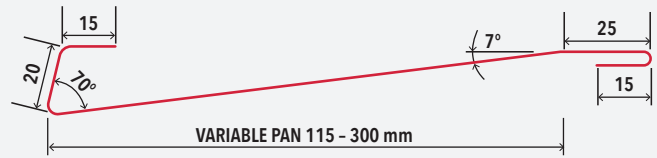

## FIXINGS

**Weatherboard Step Panel is fixed with concealed U-clips to the supporting framework.**

**Factors which can affect the lengths of the trays are:**

- Manufacturing location
- Access to work area
- Design and detailing
- Choice of profile

Please consult with TRS for technical advice.





# Long Run Profiles



## TRS 3

TRS 3 profile is a versatile profile, which can suit most residential and commercial roofing and cladding projects, whether for its low pitch capabilities or its visual appeal. Its concealed fixing system makes it ideal for harsher environments. A variety of coatings are available to suit environmental and aesthetic criteria. Grade G300 steel with minimum 0.55mm BMT. \*Only available in some locations. Please consult with The Roofing Store.

### SPECIFICATION AT A GLANCE

GENERAL	Minimum Roof Pitch	3 Degree
	Effective Cover	410mm
	Overall width	412mm
SPANS	End Span G300/0.55 BMT	1300mm
	Internal Span G300/0.55 BMT	1600mm

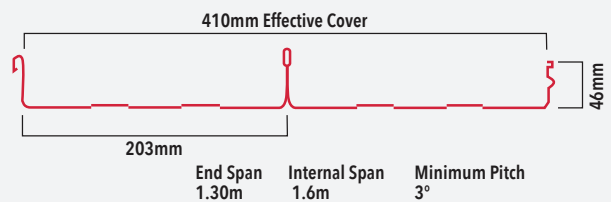

## TRS 5

TRS 5 profile is designed for residential and industrial roofing and cladding. Available in G550 grade steel with minimum 0.40mm BMT or 0.55BMT offering more resilience to damage.

### SPECIFICATION AT A GLANCE

GENERAL	Minimum Roof Pitch	3 Degree
	Effective Cover	760mm
SPANS	End Span 0.40/0.55 BMT	1100mm/1500mm
	Internal Span 0.40/0.55 BMT	1600mm/2200mm

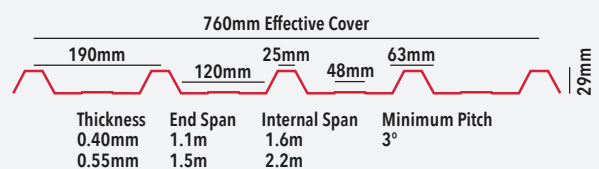



## TRS 6

TRS 6 profile has bold ribs making it an exceptionally attractive and high performance roofing and cladding product. Available in G550 grade steel with minimum 0.40mm BMT or 0.55 BMT offering more resilience to damage.

### SPECIFICATION AT A GLANCE

GENERAL	Minimum Roof Pitch	4 Degree
	Effective Cover	760mm
SPANS	End Span 0.40/0.55 BMT	1000mm/1300mm
	Internal Span 0.40/0.55 BMT	1450mm/2000mm

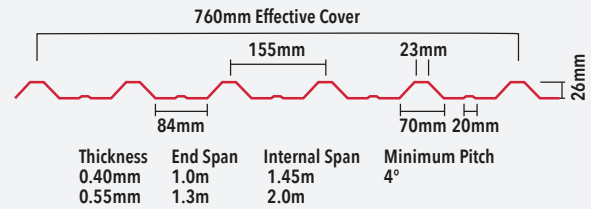

## TRS 7

TRS 7 profile is designed for residential, commercial and industrial roofing. The profile is suitable for low pitch roofing as well as curved roofing. Available in G550 grade steel with minimum 0.55 BMT offering more resilience to damage.

\*Only available in some locations. Please consult with The Roofing Store.

### SPECIFICATION AT A GLANCE

GENERAL	Minimum Roof Pitch	3 Degree
	Effective Cover	890mm
	Overall Width	934mm
SPANS	End Span 0.40/0.55 BMT	1400mm/2100mm
	Internal Span G550/0.55 BMT	1700mm/2700mm

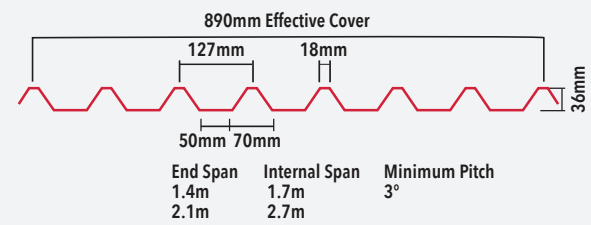

## TRS 9

TRS 9 profile is designed for commercial and industrial roofing. The profile is suitable for low pitch roofing as well as curved roofing. Available in G550 grade steel with minimum 0.55 BMT offering more resilience to damage.

### SPECIFICATION AT A GLANCE

GENERAL	Minimum Roof Pitch	3 Degree
	Effective Cover	910mm
SPANS	End Span 0.55 BMT	2300mm
	Internal Span 0.55 BMT	3200mm

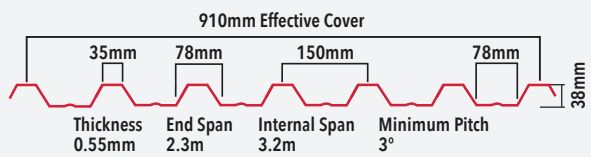

## TRS CORRUGATE

TRS Corrugate for roofing and cladding offers the timeless elegance and matchless adaptability of the traditional corrugated profile. Available in G550 grade steel with minimum 0.40mm BMT or 0.55 BMT offering more resilience to damage.

### SPECIFICATION AT A GLANCE

GENERAL	Minimum Roof Pitch	8 Degree
	Effective Cover	760mm
SPANS	End Span 0.40/0.55 BMT	700mm/900mm
	Internal Span 0.40/0.55 BMT	900mm/1300mm

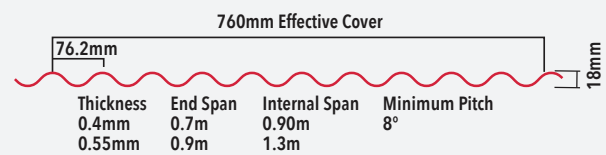



**The KiwiColour® range of pre-painted steel products have been developed specifically to withstand the higher levels of UV and salt air in the New Zealand environment.**

- Combines form, function and durability to meet your design and project requirements from roofing products and rainwater systems through to building cladding and interior.
- Opens a vast world of design possibilities for architects, product designers and manufacturers in an extensive range of colours available on our colour charts.
- Ensures a superior, longer lasting finish to steel products and is available in three paint finishes; VITOR+, VITOR+ZX or LUX, depending on your environmental and aesthetic requirements.



## Superior Technology

### LAYERS OF PROTECTION

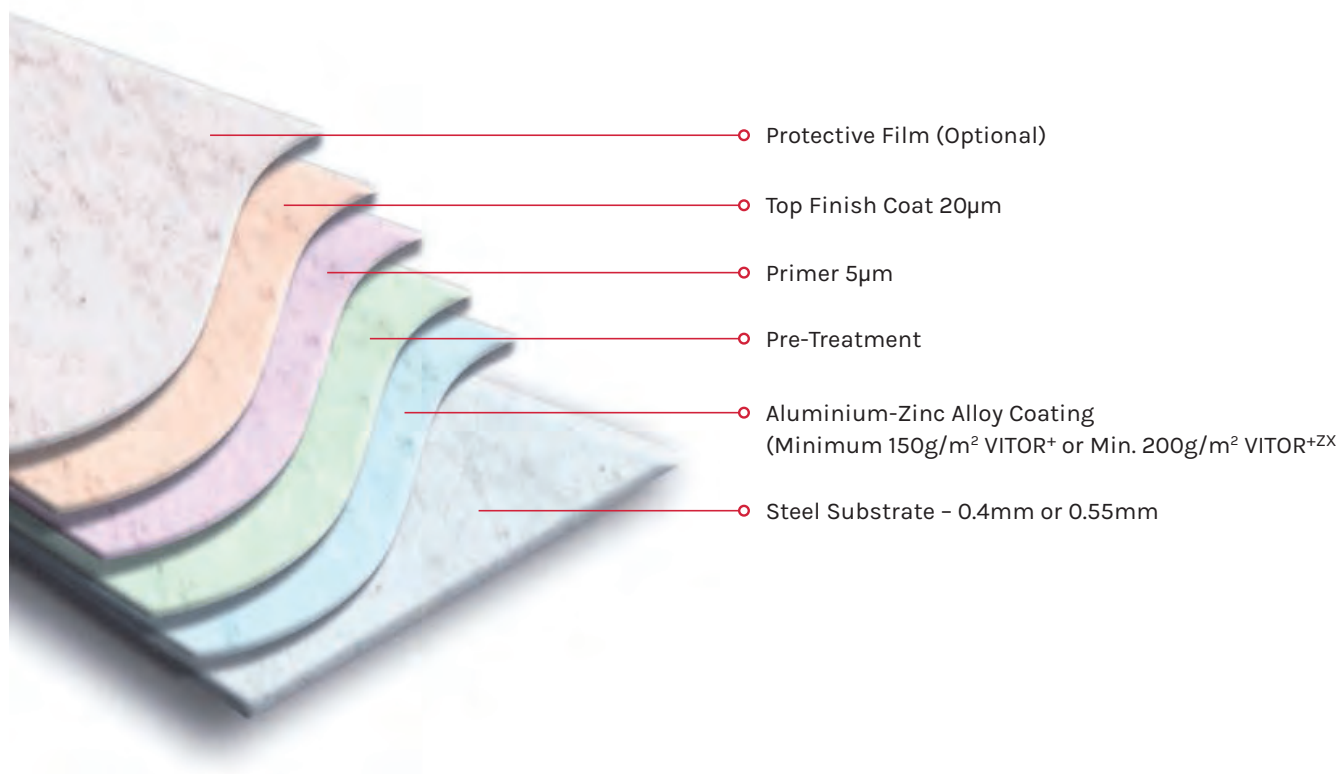

### Durability and Quality

- Hot-Dipped Alu-Zinc Coated Steel's high-performance of anti-corrosion, proven to be the best durable solution for New Zealand.
- 25µm + paint coating enhancing base metal's durability.
- 15 years + warranty back up from Kiwi Steel.
- Material manufactured from ISO 9001 certified steel mill.

### Compliance

- Manufactured specifically for use in New Zealand in accordance with standards AS 1397 and ASNZS 2728.
- Independent laboratory tested to ensure compliance with AS/NZS 2728 performance requirements in regards to corrosion resistance, salt spray performance, humidity resistance, gloss and cross hatch adhesion, and coating thickness.

### Environment

- Our Steel is 100% recyclable.
- Our material comes from an ISO 14001 Environmental Management System certified manufacturer.
- Compliance with ASNZS 2728 To ensure compliance with international and local regulations regarding chemical composition of our KiwiColour pre-painted steel, the full range of KiwiColour paint systems were tested by SGS, one of the world's largest internationally recognized independent inspection, verification, testing and certification companies. These test results showed that all our KiwiColour paints complied with standard (ASNZS 2728).



**TRS prides themselves on being at the forefront of architectural facades & has many materials available in stock and on request.**

Please consult with TRS to find the best material suited to your project.



## LUX PRE-PAINTED STEEL

Lux is a revolutionary and unique new product that will change the way you approach building materials. Experience the strength, versatility and durability of pre-painted steel while enjoying the visual appearance of other materials such as wood, zinc, corten, fabric, or hair-line.

- Lux consists of a steel base, with a zinc aluminium coating (45% zinc and 55% aluminium alloy) to a normal mass of 200g/m<sup>2</sup>.
- Lux utilises PVDF paint technology ensuring that it will withstand even the toughest of marine and industrial environments. The pre-painted and printed finishes are applied through a three bake process, further enhancing durability and corrosion resistance.
- Lux has a full range of warranties available on all its products. Warranty periods are determined by the final application and location of the building; the environmental categories are described in AS/NZS 2728:2013.

\*All Lux is available in 0.55mm base metal thickness and is suitable for a wide range of architectural roofing, internal and external wall claddings, rainwater goods and general building usage.

## LUX COATING LAYERS

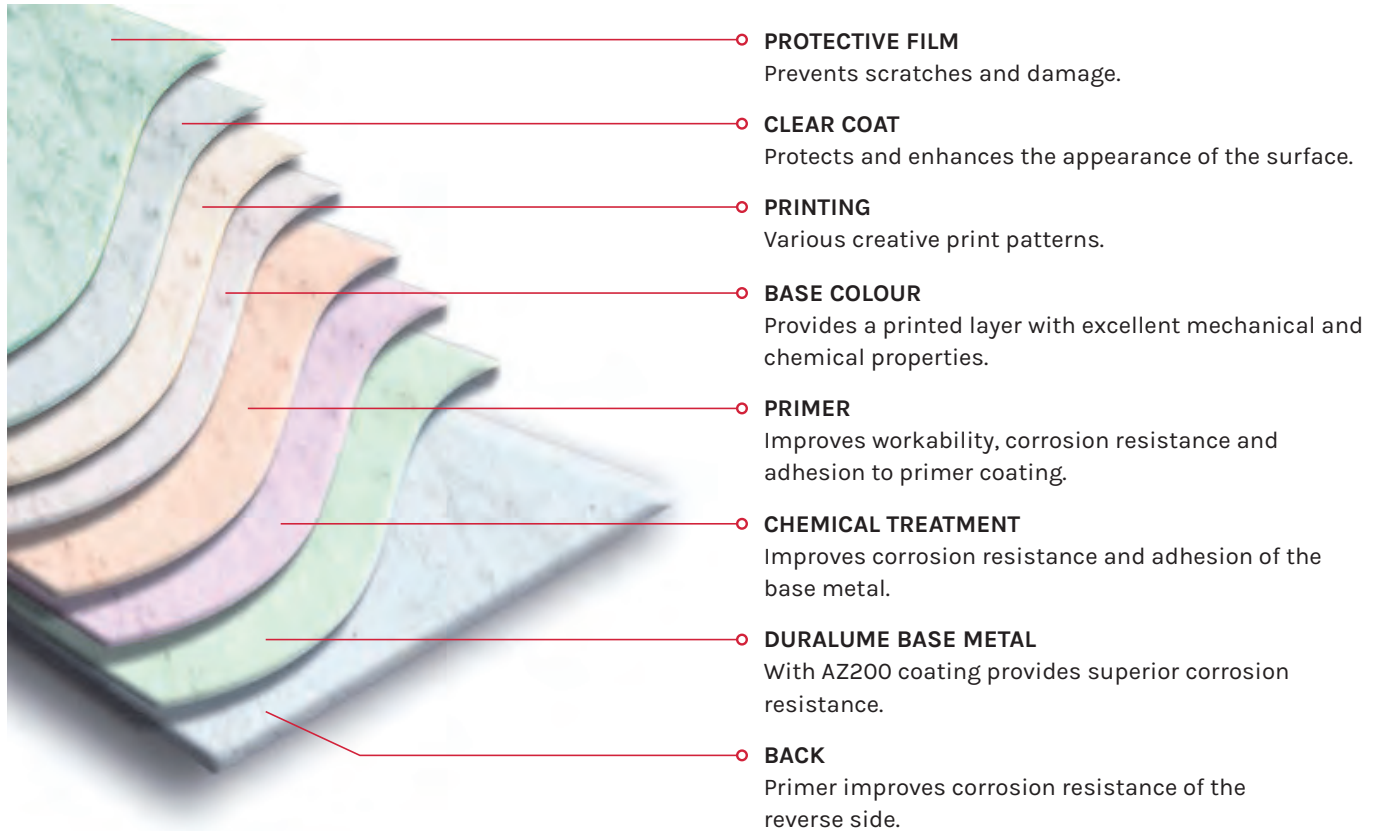

# Gallery





[www.theroofingstore.co.nz](http://www.theroofingstore.co.nz) | 0800 277 271 | [info@theroofingstore.co.nz](mailto:info@theroofingstore.co.nz)